



PXC64-U

DESIGO™ PX

Automation stations modular model with extension module

PXC...-U
PXA30-T

Freely programmable modular automation stations for HVAC and building services systems. The P-bus connection allows a flexible data point mix in order to meet all necessary requirements of the various plant systems.

- 64 or 128 load units per stations
- P-bus for connection of external I/O modules
- Large selection of I/O modules
- Management functions (alarm management, time schedulers, trend functions, remote management, access protection, etc.)
- Stand-alone application or use as interconnected devices/systems
- Additional configuration memory (extension module)
- Connection of PXM20 operator unit
- Connection of QAX... room units
- Standard communication BACnet over LON

Functions

These freely programmable automation stations provide the infrastructure for the provision and processing of system-specific and application-specific functions. Apart from the freely programmable control functions these units comprise integrated convenient management functions such as:

- Alarm management with alarm routing throughout the whole network. Three level alarm management (simple, basic and enhanced) with safety control transmission and automatic transmission monitoring
- Time schedulers
- Trend functions
- Remote management functions
- Access protection for the whole network with individually defined user profiles and categories

Programming language

These automation stations are freely programmable with the D-MAP programming language (follows closely CEN Standard 1131). All function blocks available in libraries are graphically linked with the plant operating programs.

Communication

The devices communicate via an open bus system in accordance with the international standard BACnet protocol. Integrated peer-to-peer communication with other automation stations and also with PXM20 operator units.

PXA... Extension modules

Modem interface

The PXA30-T extension module provides a modem connection (D-Sub 9 pin).

Types

Device	Type
Automation station for 64 load units*	PXC64-U
Automation station for 128 load units*	PXC128-U
Extension module with modem interface	PXA30-T

* 1 load unit = 12.5 mA

Compatibility

I/O modules

Device	Type	Data sheet
I/O modules with basic functions measuring, signalling, switching and controlling	PTM1..	8111 to 8171

Operator units

The automation stations are operated with the convenient PXM20 operator unit with control buttons as well as displays in graph form and clear text. The PXM20 unit can be used either locally or decentralised for all plant connected together in one network.

Room units

Up to five room units QAX... can be operated via the PPS2 bus connection.

The data between the automation station and the I/O modules are exchanged via the 3-core P-bus.. Each module on the same P-bus is provided with its own address between 1 and 255. The addresses are set with address plugs.

The automation stations provide the connected I/O modules with a DC 23 V supply. The automation station load by I/O modules is expressed by the number of load units of 12.5 mA each (details of the calculation of the total load see the I/O module range document CM2N8100).

Design

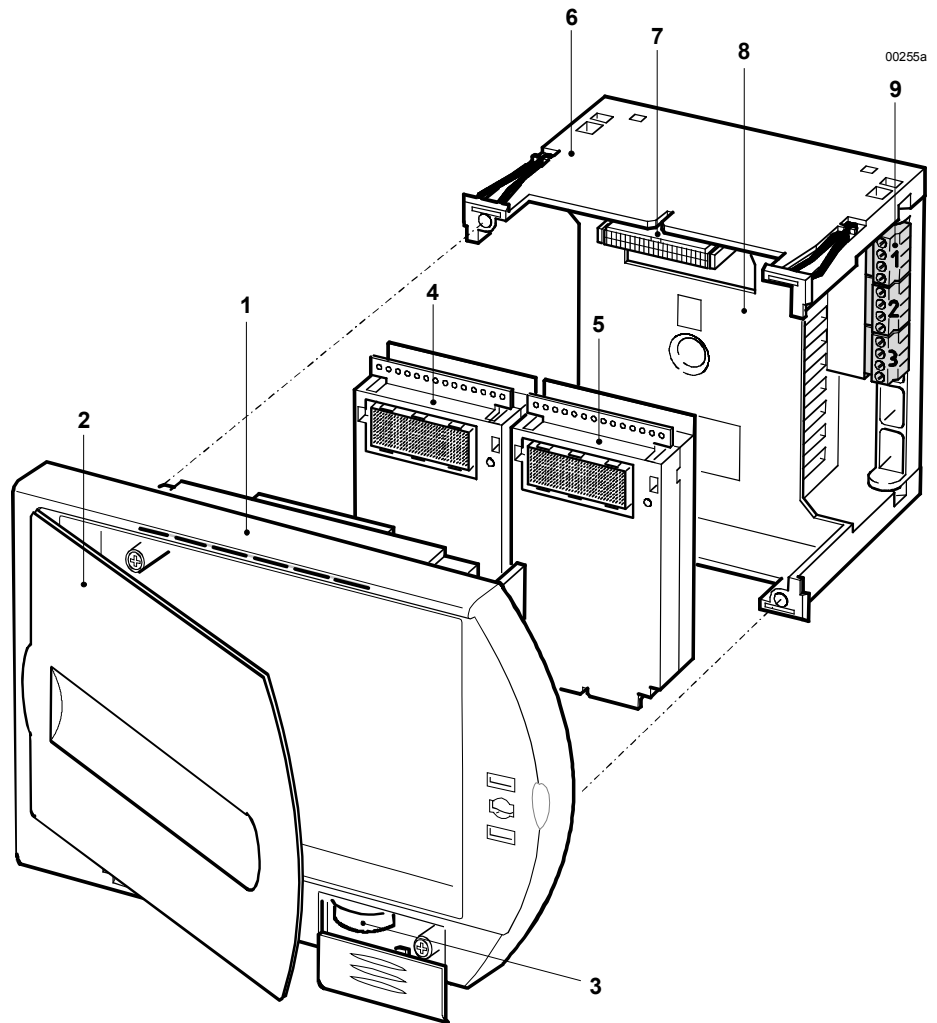

1	Plug-in unit
2	Front cover (a PXM20 operator unit can be fitted instead of the front cover)
3	Battery
4/5	Extension modules
6	Device socket
7	Plug-in connection for automation station for device supply and bus electronics
8	Housing with pcb for device supply
9	Plug-in terminal blocks with reversible support bar (here used for wall mounting)

LED indicators

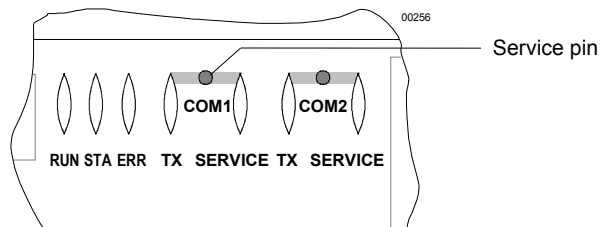

LED	Colour	Status	Function
RUN	Green	Continuously off	No supply
	Red	Continuously on	Supply ok, firmware ok
STATUS	Red	Continuously on	RESET key pressed
		Continuously off	Normal operation
		Quick flashes	Hardware fault detected during self-test or automation station in "coma" operating state No validly licensed firmware
INFO	Red		Freely programmable
TX COM1 COM2	Yellow	Flashing	Data traffic on LON bus Not implemented
SERVICE COM1	Red	Continuously off	LON node is configured
COM2		Flashing	LON node is not configured
		Flashing acc. to wink command pattern *	Physical identification of automation station after receiving wink command
		Continuously on	LON chip defect or service key was pressed again
			Not implemented

* Wink command rhythm pattern:

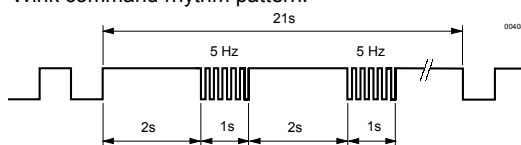

Disposal



The unit contains electric and electronic components and must not be disposed of with domestic waste. Lithium battery, printed circuit board and housing must be disposed of separately

The local and actual regulations must be observed.

Mounting instructions

The modular automation stations are particularly suitable for control panel front mounting as well as flush-panel and wall mounting.

For control panel front mounting the device socket is held in place by clamps at all four corners (no tools required for mounting). For flush panel mounting the plug-in terminal blocks can be repositioned whilst at the same time reversing the support bars to enable front access. The support bars absorb the screw force and also provide the means of fixing the device to the wall.

Instead of the front cover a PXM20 operator unit can be fitted on the modular automation station. The upper housing is fixed to the device socket with two screws.



Note!

Insert the **PXA30-T extension module** fully into its socket (to a depth of 1.5 mm), using slight force. Then **check that the plug is safely snapped on** to ensure safe and smooth functioning.

Commissioning

In order to prevent equipment damage and/or personal injuries always follow local safety regulations and the required safety standards.

Loading plant operating program

Download the plant operating program to the automation station with the PX Design tool in the DESIGO TOOLSET, direct via the RJ45 connector or the LON bus.

Setting parameters and configurations

Use the PX Design tool in the DESIGO TOOLSET for setting the control parameters and the configuration data. Data visible in the network can also be changed with the PXM20 operator unit.

Wiring test

It is possible to test field devices and the wiring as soon as the power supply is connected, without first downloading the plant operating program. The test is carried out with the PXM20 operator unit.

Network connection

The network addresses are configured with the DESIGO TOOLSET. In order to provide a unique identification in the LON network press the service pin with a sharp implement (COM1 on the front, see page 4) or send a wink command to the relevant automation station (service LED flashes).

Service functions

Three service buttons are provide under the front cover:

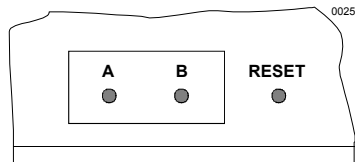

A	Force Firmware Download: If this key is pressed during a restart (Powerfail) the current D-MAP program is deleted from the FLASH. The automation station waits a short while for the signal to activate the FWLoader and then starts the automation station.
B	Force Cold Start: Pressing this button during a restart forces a cold start.
RESET	Forces a restart

Maintenance

Battery life

Lithium batteries usually have a life span of at least four years. The automation station automatically sends a system event in order to indicate a low charge. After the "Battery low" event there are several months of remaining life span.

Battery change

To change the battery remove the front cover. As long as there is an external power supply, the battery may be removed for unlimited time.



Caution!

To prevent hardware damage by electrostatic discharge (ESD), a wrist strap with earth cable must be used during the battery change.

Technical data

General device data

Operating voltage	AC 24 V ± 20 %
Safety extra-low voltage SELV	
Protective extra-low voltage PELV	HD 384
Frequency	50/60 Hz

Current consumption

4 A

Power consumption

PXC64-U 45 VA

PXC128-U 95 VA

Internal fuse

Thermic, automatic reset

Operating data

Processor

MOTOROLA Power PC

	Memory space	FLASH	16 MByte
		SDRAM	32 MByte
		SRAM	2 MByte
	Data backup in case of power failure		
	Applications, parameter (FLASH)		> 10 years
	Run-time data (battery)		> 4 years (battery)
LON bus interface	Network		TP/FT-10
	Baud rate		78 kBit/s
	Protocol		BACnet
P-bus interface	Polling cycle at I/O modules		0.3 s
	Transmission speed		62.5 kBaud
	Signal level		DC +23 V and 0/-5 V
Interface, room units	Interface type		PPS2
	Supply class		4
	PPS2 baud rate		4.8 kBit/s
Plug-in screw terminal	Power supply and signals		Stranded of solid conductors, 0.25 ... 2.5 mm ² or 2 x 1.5 mm ²
	LON bus		Stranded or solid conductors, 2 x 1.0 mm ²
Modem interface	Interface type		RS232
	Baud rate /		38400 (may be configured) /
	Data bits / Stop bits / Parity / Flow control		8 / 1 / one / Xon/Xoff
Single cable lengths	Interface, room unit		Max. 125 m where A = 1.0 mm ²
	Cable type		4-core, twisted pair, unscreened
	Capacitance per unit length		Max. 56 nF/km
	LON bus		Max. 450 m in free topology Max. 900 m in serial topology
	Cable type		2-core, twisted pair, unscreened
	P-bus		Max. 50 m
	Cable length, special requirements		Max. 300 m
	Cross-section		Min. 3 x 0.75 mm ²
	Connecting cable PXM20/DESIGO TOOLSET		Max. 3 m
	Modem cable type		9-core standard screened cable
	Cable length		Max. 3 m
Housing protection standard	Protection standard to EN 60529		IP 30
Protection class	Isolation protection class		II
Ambient conditions	Operation		Class 3K5 to IEC 721
	Temperature		0 ... 50 °C
	Humidity		< 85 % rh
	Transport		Class 2K3 to IEC 721
	Temperature		- 25 ... 65 °C
	Humidity		< 95 % rh
Industry standards	Product safety		
	Automatic electronic controls for household and similar use		EN 60730-1
	Special requirements for energy controllers		EN 60730-2-11
	Electromagnetic compatibility		
	Interference immunity		EN 50082-2
	Emitted interference		EN 50081-1
	Meets requirements for CE marking:		
	Electromagnetic compatibility		89/336/EEC
	Low Voltage Directive		73/23/EEC
Dimensions	<i>See "Dimensions"</i>		

Connection terminals

PXC64-U

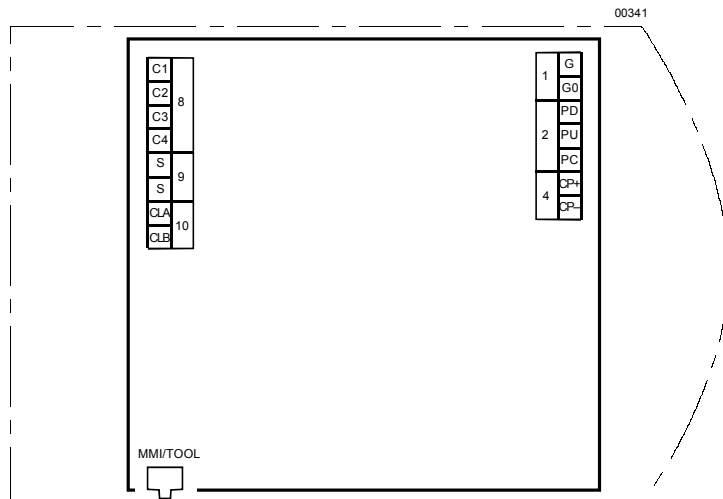

G/G0	Supply voltage AC 24 V/PELV
PD	P-bus Synchronisation cable
PU	Data transmission line, bi-directional
PC	Reference voltage DC 23 V (against G0)
CP+/CP-	PPS2 bus (for QAX... room operator units)
CLA/CLB	LON bus
MMI/TOOL	RJ45 socket on front cover (for PXM20 operator unit or DESIGO TOOLSET)

PXC128-U

The PXC128-U includes a second P-bus:

- Terminals P-bus 1 PD1, PU1 and PC1
- Terminals P-bus 2 PD2, PU2 and PC2

Tool socket

Standard RJ45 tool socket for LON devices.

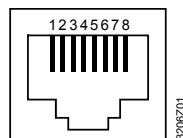

1	LON, Data A (CLA)	5	Unoccupied
2	LON, Data B (CLB)	6	Unoccupied
3	G0, GND	7	COM1/TxD
4	G/Plus	8	COM1/RxD

Modem-interface (on the PXA320-T extension module)

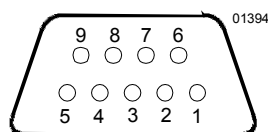

1	DCD	data carrier detect
2	RXD	received data
3	TXD	transmit data
4	DTR	data terminal ready
5	GND	signal ground
6	DSR	data set ready
7	RTS	request to send
8	CTS	clear to send
9	NC	not connected

Connection diagrams

Connection of field devices see mounting and installation handbook for I/O modules and P-bus (CM2M8102).

Dimensions

Front mounting

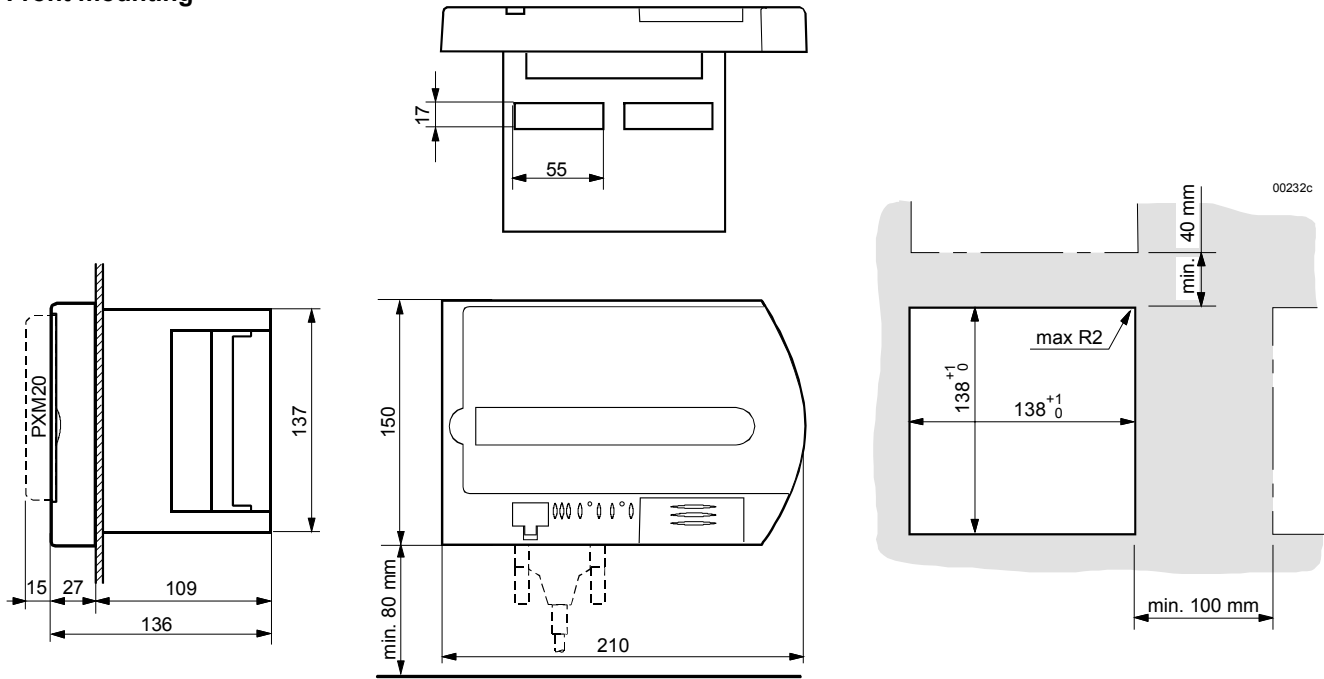

Wall mounting

